

## Padded Folding Shower Seats Rectangle with Legs

HH-2414P.4LEGS

### Application Use:

Architectural

Commercial

Institutional

Residential

### Specifications

Folding shower seat manufactured from 1" (25mm) diameter, 18 gauge and 1.25" x 1.25" (32mm x 32mm), 16 gauge, type 304 stainless steel tubing with #4 satin finish. Wall mount brackets shall be 12 gauge type 304 stainless steel. Padded vinyl cushion shall have 1.5" (38mm) high density, high resilience foam, covered with fire and mildew resistant, UV inhibited, marine grade naugahyde. Waterproof seam cushions shall have no external piping. Seat unit shall comply with all applicable federal, provincial and local building and safety codes.



Custom sizes are available to suit special requirements.

24" x 16"	(609mm x 406mm)	White	Model # HH-2414P.4LEGS
24" x 16"	(609mm x 406mm)	Almond	Model # HH-2414P.4LEGSAL

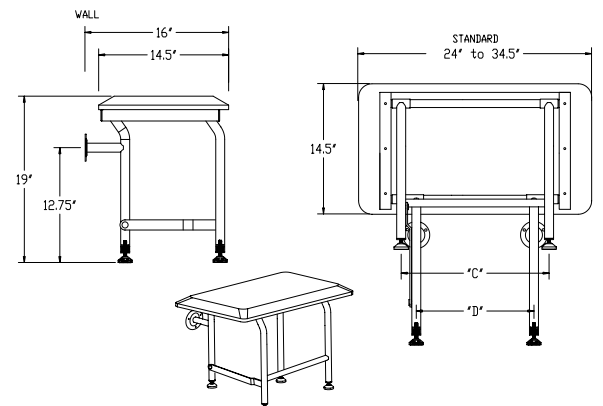

Shower Seats have been designed and tested to withstand 600lbs. (272kgs) of load when properly installed.\* This exceeds HUD, FHA, VA, ADA, ANSI and other federal, provincial, and local codes. \*Shower seats can only be as strong as what they are mounted to. It is imperative when installing any shower seat to consult with a qualified contractor to insure you have sufficient backing.

SEAT SIZE	24	26	28	30	32	34.5"
LEG WIDTH "C"	14.4	16.4	18.4	20.4	22.4	24.9
LEG WIDTH "D"	11.1	13.1	15.1	17.1	19.1	21.6