



health at home, inc.
Enhancing Safety, Vitality & Longevity at Home

Bilanx bathing collection®

strike the balance Design Safety

HH-2621P.4LEGS RH-LH SPECIFICATION SHEET

Specifications

Folding shower seat made from 1" (25mm) diameter, 18 gauge and 1.25" x 1.25" (32mm x 32mm), 16 gauge, type 304 stainless steel tubing with #4 satin finish. Wall mount brackets shall be 12 gauge type 304 stainless steel. Padded vinyl cushion shall have 1.5" (38mm) high density, high resilience foam, covered with fire and mildew resistant, UV inhibited, marine grade naugahyde. Waterproof seam cushions shall have no external piping. Seat unit shall comply with all applicable federal, provincial and local building and safety codes.



**** RIGHT HAND SHOWN , LEFT HAND OPPOSITE ORIENTATION ****

26" x 21" (660mm x 533mm) White Model # HH-2621P.4LEGS RH
26" x 21" (660mm x 533mm) White Model # HH-2621P.4LEGS LH

Safety Note

These Shower Seats have been designed and tested to withstand 600lbs. (272kgs) of load when properly installed.* This exceeds HUD, FHA, VA, ADA, ANSI and other federal, provincial, and local codes. *Shower seats can only be as strong as what they are mounted to. It is imperative when installing any shower seat to consult with a qualified contractor to insure you have sufficient backing.

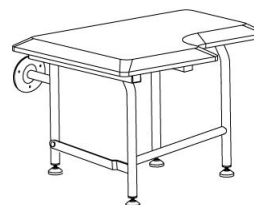
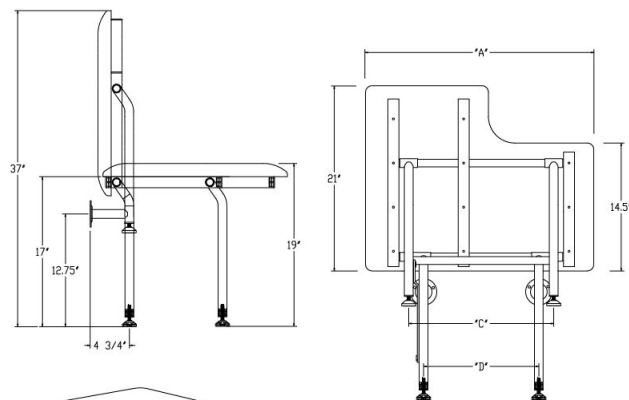

Right Hand (shown)
Left Hand (opposite)

SEAT SIZE "A"	26
LEG WIDTH "C"	16.4
LEG WIDTH "D"	13.1

ORDER ENTRY BY FAX 888.802.8186 OR EMAIL orders@healthathomeinc.com
Office 704.960.0148 or 980.900.2845 www.healthathomeinc.com

Products that enhance safety, vitality, & longevity at home.