



health at home, inc.
Enhancing Safety, Vitality & Longevity at Home

Bilanx bathing collection®

strike the balance Design Safety

RH6-St. Croix

Model RH6 is a freestanding or built-in, 60-gallon side access bathing tub.

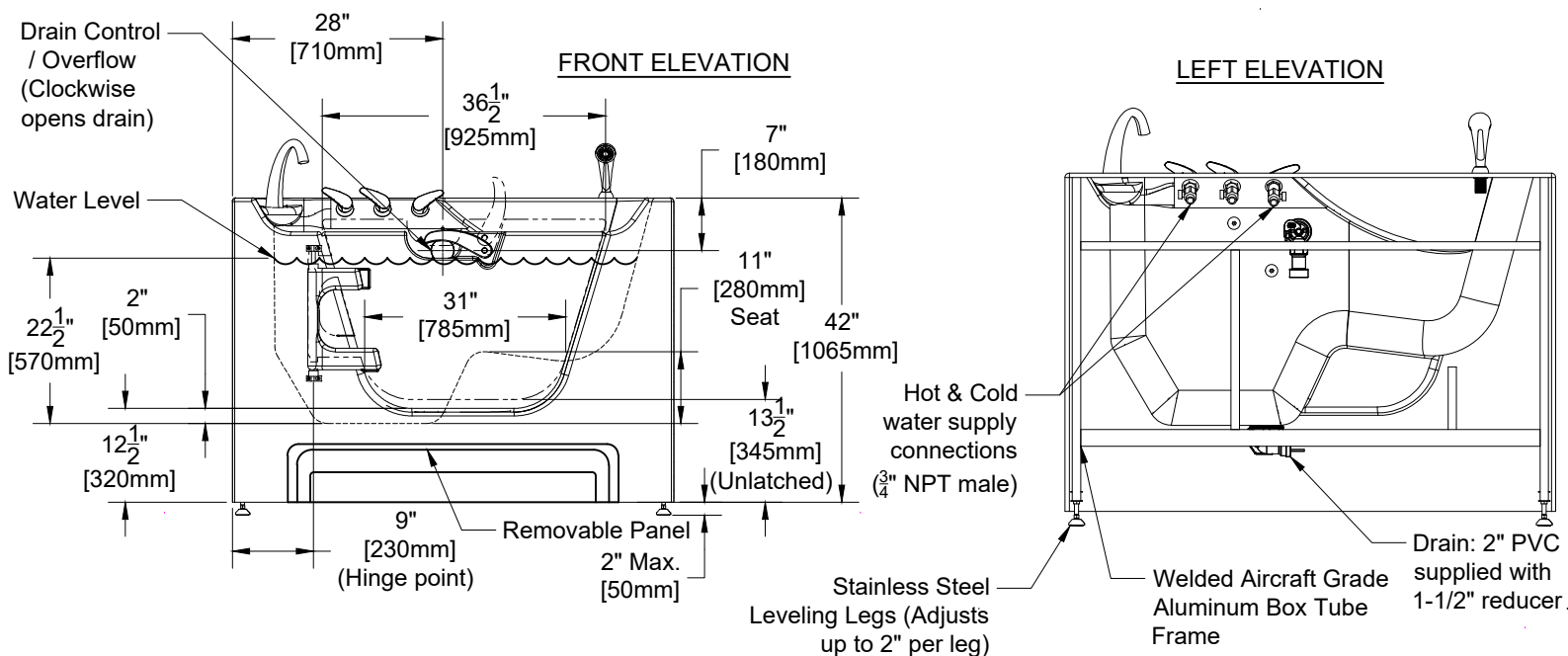

PRODUCT SPECIFICATIONS:

- Walk in style bathtub with an outward left or right swinging door.
- Hot & Cold Water Supply Connections: $\frac{3}{4}$ " NPT - male
- Factory installed overflow and cable drain assembly.
- Handheld shower, bathtub spout /diverter and water valves.
- One (1) removable front access panel.
- Reinforced & slip resistant floor.
- Bathwell Capacity (unoccupied - at overflow level): 60 gallons; water depth 22 1/2" [570mm] from tub floor.
- Drain Outlet: 2" PVC. Includes a 2" to 1-1/2" PVC reducer shipped loose..
- Weight Capacity (occupant): 400Lbs [182Kg]
- Weight Occupied (tub, w/max. capacity water & occupant): 840Lbs [380Kg]
- Shipping Weight w/Skid: 290Lbs [130Kg] approx.

ORDER ENTRY BY FAX 888.802.8186 OR EMAIL orders@healthathomeinc.com

Office 704.960.0148 or 980.900.2845 www.healthathomeinc.com

Products that enhance safety, vitality, & longevity at home.



health at home, inc.
Enhancing Safety, Vitality & Longevity at Home

Bilanx bathing collection®

strike the balance Design Safety

RH6-St. Croix

Model RH6 is a freestanding or built-in, 60-gallon side access bathing tub.

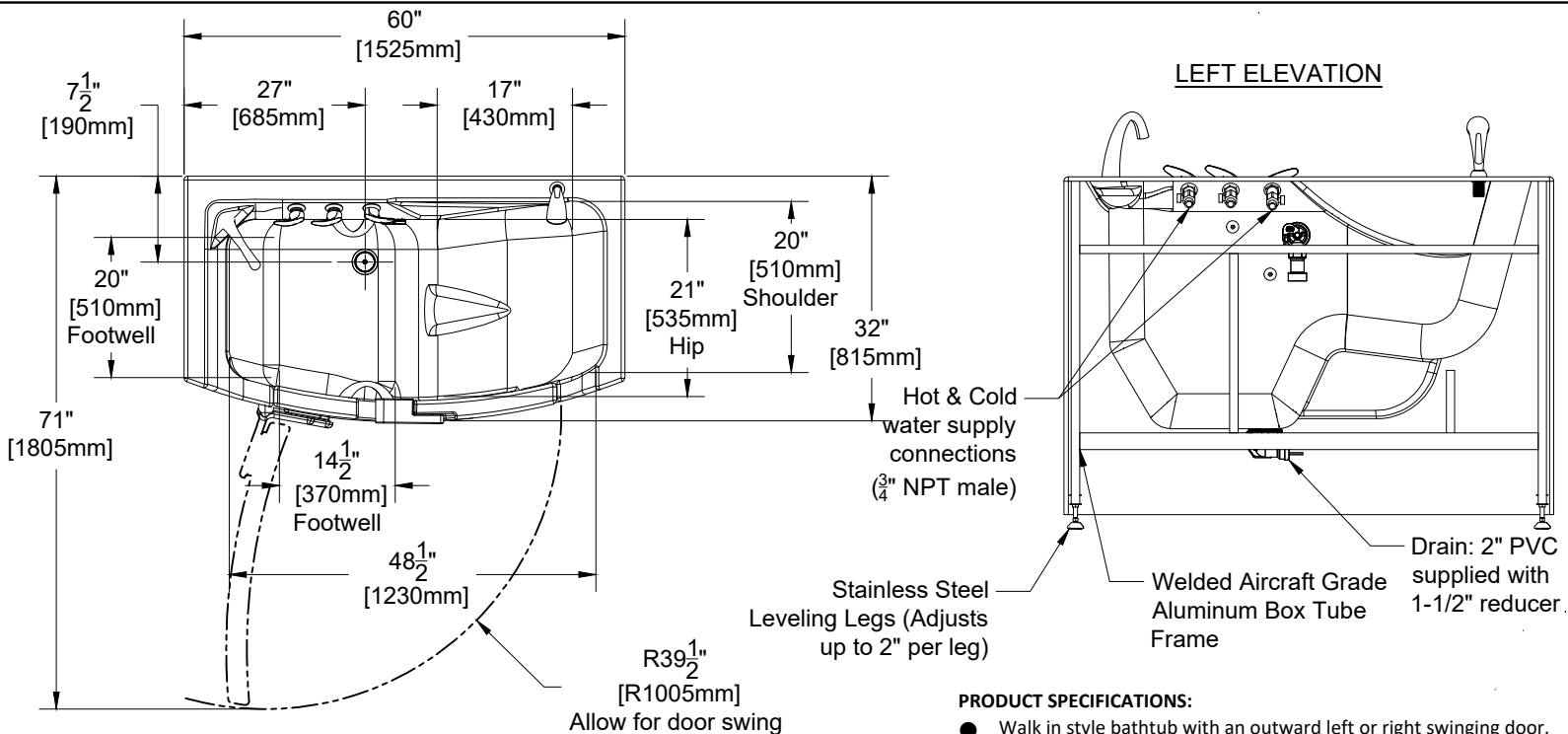

PRODUCT SPECIFICATIONS:

- Walk in style bathtub with an outward left or right swinging door.
- Hot & Cold Water Supply Connections: 3/4" NPT - male
- Factory installed overflow and cable drain assembly.
- Handheld shower, bathtub spout /diverter and water valves.
- One (1) removable front access panel.
- Reinforced & slip resistant floor.
- Bathwell Capacity (unoccupied - at overflow level): 60 gallons; water depth 22 1/2" [570mm] from tub floor.
- Drain Outlet: 2" PVC. Includes a 2" to 1-1/2" PVC reducer shipped loose..
- Weight Capacity (occupant): 400Lbs [182Kg]
- Weight Occupied (tub, w/max. capacity water & occupant): 840Lbs [380Kg]
- Shipping Weight w/Skid: 290Lbs [130Kg] approx.

ORDER ENTRY BY FAX 888.802.8186 OR EMAIL orders@healthathomeinc.com

Office 704.960.0148 or 980.900.2845 www.healthathomeinc.com

Products that enhance safety, vitality, & longevity at home.