



Flip-up Grab Bar
Sold Separately

health at home, inc.
Enhancing Safety, Vitality & Longevity at Home

Bilanx bathing collection[®]

strike the balance Design Safety

HH-FM-BS/HH-FM-WH

Specifications

In room floor mounted support carriers manufactured of heavy gauge all stainless steel construction and is available to permanently mount Flip-up Safety rails. In room carriers securely mount to the floor and hold the flip up rail to the standard height of 33" to the top of the rail. Flip-up grab bars are designed, built, and tested to withstand 250lbs (113kgs) of vertical load when properly installed. Installation should be completed by a qualified tradesman to ensure that the assembly will support the load for which it is intended.

Stainless Steel Finish

HH-FM-BS

Painted White

HH-FM-WH

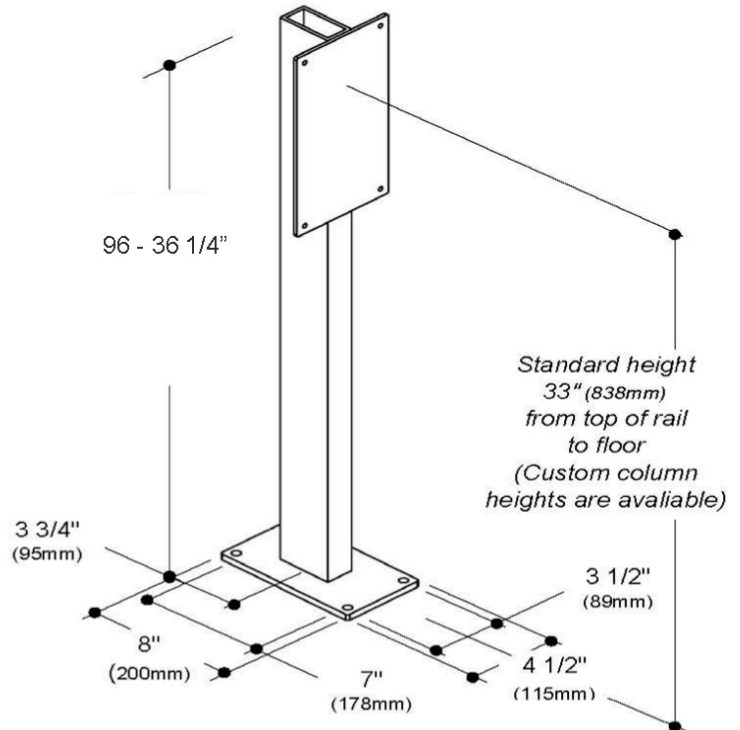

ORDER ENTRY BY FAX 888.802.8186 OR EMAIL orders@healthathomeinc.com
Office 704.960.0148 or 980.900.2845 www.healthathomeinc.com
Products that enhance safety, vitality, & longevity at home.