

## Wall to Floor w/Outrigger - right & left

\*wingit compatible

Configuration: 15-16

Grab Bar

Twist-Lock Concealed

### Application Use:

Architectural

Commercial

Institutional

Residential

### Specifications

Wall to Floor Safety Bar with outrigger and snap on / twist-lock concealed flanges.

Manufactured by ELCOMA from 18 gauge, type 304 stainless steel, satin finished, tubing. 14 gauge stainless steel mounting flanges, heliarc welded to the tube to form a single structural unit.

ELCOMA grab bars are designed, built, and tested to withstand 250lbs. (113kgs) of load when properly installed.\* This exceeds HUD, FHA, VA, VA, ADA, ANSI and other federal, provincial, and local codes. \*Grab Bars can only be as strong as what they are mounted to. It is imperative when installing any safety product to consult with a qualified contractor to insure you have sufficient backing.

*Configuration #15 (right hand) shown*



## Custom sizes are available to suit special requirements.

The exclusive ELCOMA concealed flange system adapts both "Twist-Lock" and "Snap-On" compatibilities making installation a breeze. ELCOMA Wall to Floor Bars come in 1.25" & 1.5" Diameters with a variety of finishes & coatings.

Bar Diameter:	1.25" , & 1.5"
Bar Grip:	Smooth, Peened, Knurled, Shur-Grip (available in 1.25" only)
Standard Flange:	Twist-Lock / Snap-On concealed * Wingit compatible
Optional Flanges:	Bolt, Exposed, & Female Thread Insert
Standard Finishes:	Satin Finish, White or Almond Powder Coating
Custom Finishes:	Multiple colors & finishes available, call your representative or visit <a href="http://www.elcoma.com">www.elcoma.com</a> for selection grid.
Configurations:	Standard: 33"x30"

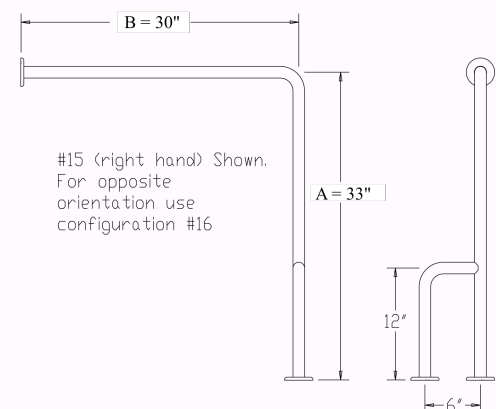

ORDER ENTRY BY FAX 888.802.8186 OR EMAIL [orders@healthathomeinc.com](mailto:orders@healthathomeinc.com)

Office 704.960.0148 or 980.900.2845 [www.healthathomeinc.com](http://www.healthathomeinc.com)

*Products that enhance safety, vitality, & longevity at home.*