

# Comfort Series SUBMITTAL DATA

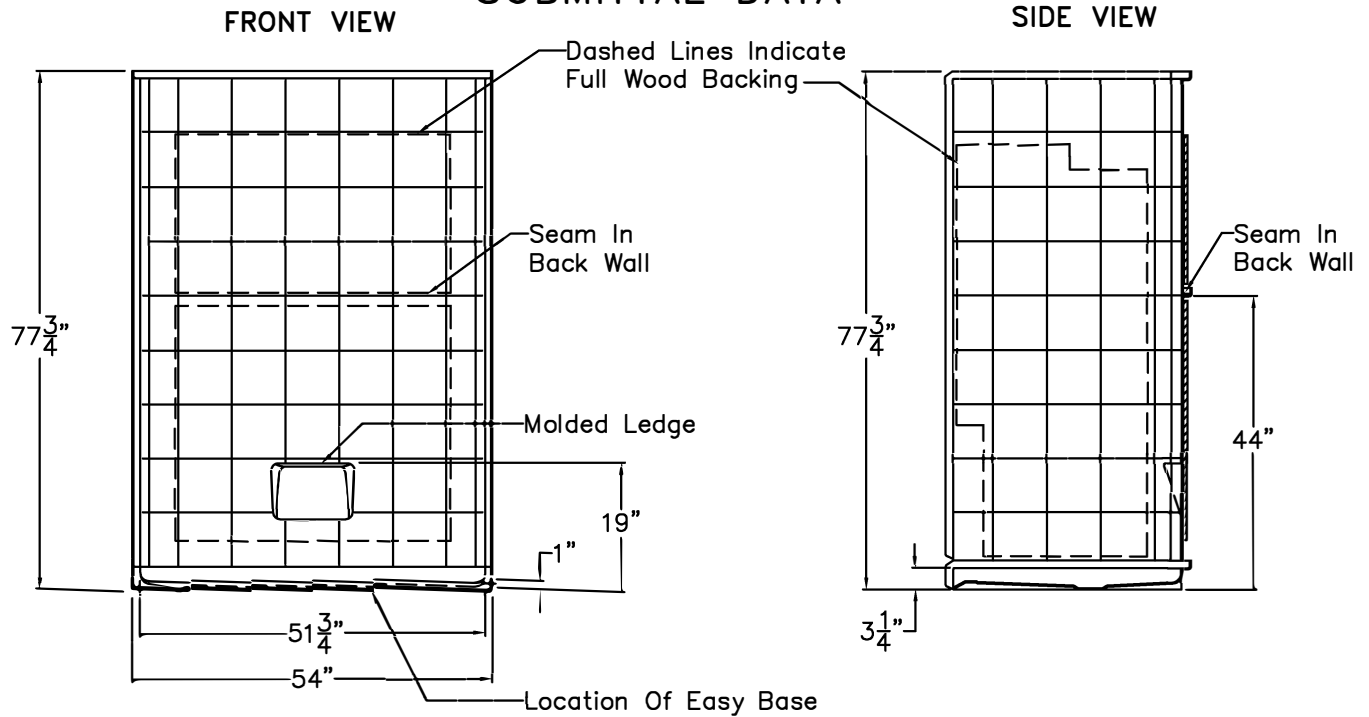

**TOP VIEW**

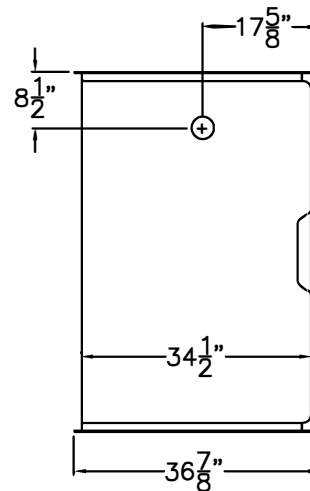

## Sectional Shower

This shower enclosure shall be Aquarius Model MP 5436 BF 5P 1.0 left or right drain location. Finished surface shall be of sanitary-grade applied acrylic. The unit shall have outside dimensions of 54" x 36 7/8" x 77 3/4". The unit shall meet IAPMO Z124-2011, and CSA B45.5-11.

The enclosure shall be equipped with the following factory installed accessories:

- 1) Molded lower ledge on back wall,
- 2) Tile finish,
- 3) Five piece sectional design,
- 4) Full wood backing on all walls,
- 5) Factory installed Easy Base self sustaining bottom,
- 6) Left or right hand drain location,
- 7) 1.0" threshold.

## Detail of 1.0" Threshold

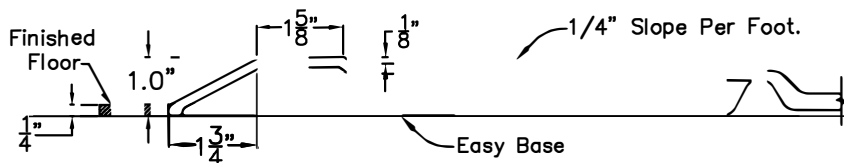

DUE TO THE NATURE OF THE MATERIALS INVOLVED  
UNIT DIMENSIONS MAY VARY ± 1/2 INCH

Health at Home, Inc.

Approved By Print Name:

Drawing#: MP 5436 BF 5P 1.0 L-R

Approved By Signature:

Date:

Date: 3-31-09

Revised: 10-19-16

Rep.:

Wholesaler:

Quote No.

ORDER ENTRY BY FAX 888.802.8186 OR EMAIL [orders@healthathomeinc.com](mailto:orders@healthathomeinc.com)

Office 704.960.0148 or 980.900.2845 [www.healthathomeinc.com](http://www.healthathomeinc.com)

*Products that enhance safety, vitality, & longevity at home.*

# Board Placement Drawing

SUBMITTAL DATA © 2004

FRONT VIEW

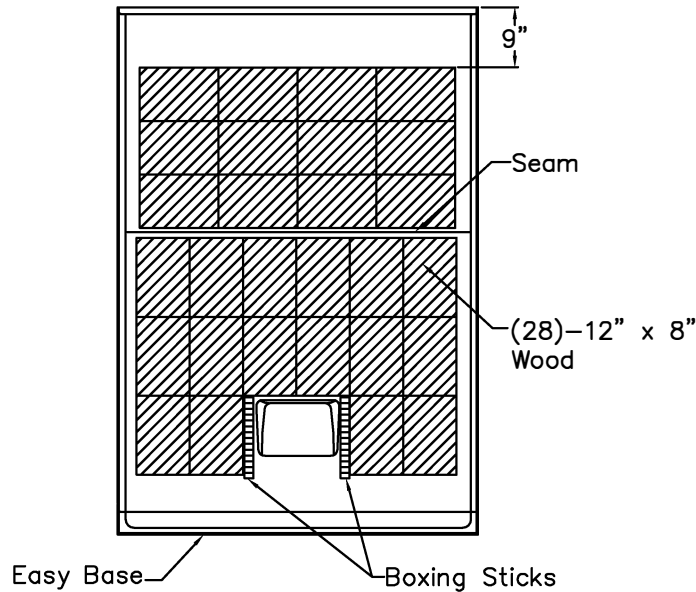

SIDE VIEW

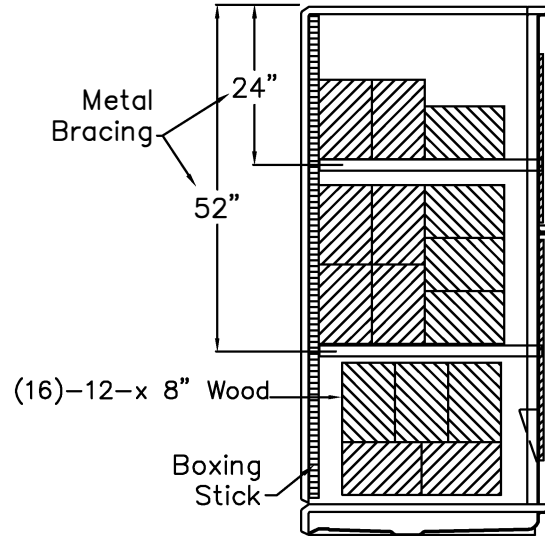

SIDE VIEW

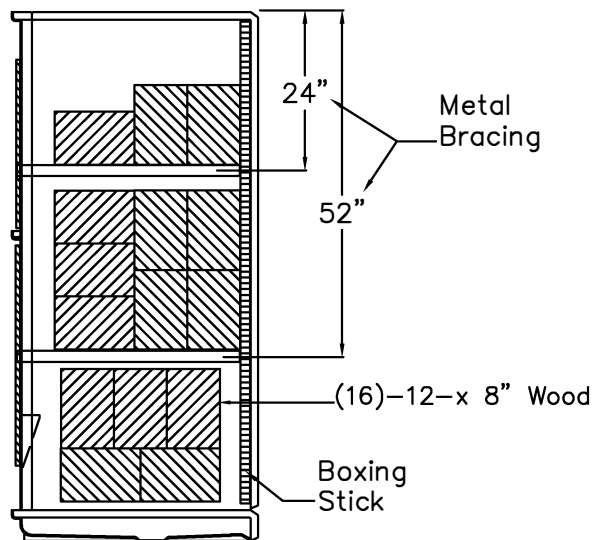

DUE TO THE NATURE OF THE MATERIALS INVOLVED  
UNIT DIMENSIONS MAY VARY ± 1/2 INCH

Job Name:	Health at Home, Inc.	
Approved by Print Name:	Drawing#: MP 5436 BF 5P 1.0 L-R-BP	
Approved by Signature:	Date:	Date: 12-21-09      Revised: 10-19-16
Rep.:	Wholesaler:	Quote No.:

ORDER ENTRY BY FAX 888.802.8186 OR EMAIL [orders@healthathomeinc.com](mailto:orders@healthathomeinc.com)

Office 704.960.0148 or 980.900.2845 [www.healthathomeinc.com](http://www.healthathomeinc.com)

*Products that enhance safety, vitality, & longevity at home.*